

## WARNINGS

### Risk of electrical shock

- **ALL ELECTRICAL CONNECTIONS MUST BE PERFORMED BY A LICENSED ELECTRICIAN AND MUST CONFORM TO ALL NATIONAL, STATE AND LOCAL ELECTRICAL CODES IN EFFECT AT THE TIME OF INSTALLATION INCLUDING ENSURING PARTS ARE INSTALLED IN THE CORRECT ZONE AND EQUIPOTENTIAL BONDING IS CARRIED OUT IF REQUIRED.**
- **The appliance should be supplied through a residual current device (RCD) having a rated residual operating current not exceeding 30mA.**
- The appliance must be connected to a suitable rated and weather protected power supply. The supply line should be a dedicated power circuit and means for disconnection must be incorporated in the fixed wiring in accordance with your local wiring regulations. Means for disconnection from the supply mains should have a contact separation in all poles that provide full disconnection under over voltage Category III conditions.
- Earthed appliances must be permanently connected to fixed wiring.
- The appliance contains no serviceable parts. Do not attempt service of this control pack. Contact your dealer or authorised service agent for assistance.
- Turn the mains power OFF before servicing appliance or modifying any cable connection.
- Suitable for indoor use only or when installed under a weatherproof spa skirt. The appliance should be installed in an enclosure such that all electrical connections cannot be accessible to the user without the use of a tool.
- Low voltage or improper wiring may cause damage to this appliance. Read and follow all wiring instructions when connecting to power supply.
- If the supply cord is damaged it must be replaced by the manufacturer, its service agent, licensed electrician or similarly qualified persons in order to avoid a hazard.
- To prevent electric shock hazard and/or water damage to this appliance, all unused receptacles must have a water proof seal in place.
- Parts incorporating electrical components must be located or fixed so that they cannot fall into the bath or spa.
- Parts containing live parts, except parts supplied with safety extra-low voltage not exceeding 12V must be inaccessible to a person in the bath or spa.
- This appliance must NOT be installed in proximity to highly flammable materials.
- Water temperature in excess of 38°C may cause hyperthermia (heat stress).
- It is the spa manufacturer's and/or installer's responsibility to select suitable loads and configure load shed settings (if required) to ensure the system does not exceed its rated maximum total load.
- It is the installer's responsibility to ensure the floor can support the expected load of the bath or spa and an adequate drainage system has to be provided to deal with overflow water.
- A whirlpool spa should incorporate a water filtration system where the required level of water purity can be achieved.
- An adequate drainage system must be provided if the equipment is to be installed in a pit.
- This appliance is not intended for use by persons (including children) with reduced physical, sensory or mental capabilities, or lack of experience and knowledge, unless they have been given supervision or instruction concerning use of the appliance by a person responsible for their safety.
- Children should be supervised to ensure that they do not play with the appliance.

# ELECTRICAL INSTALLATION

- All electrical connections must be performed by a licensed electrician and must conform to all national, state and local electrical codes in effect at the time of installation.
- The appliance should be supplied through a residual current device (RCD) having a rated residual operating current not exceeding 30mA.
- The supply line should be a dedicated power circuit. The installer should consider the sum total load of all devices connected to the SV Mini controller when determining the size of the power circuit and install an appropriately sized circuit breaker to suit. Ensure circuit breaker is rated for motor start up currents. Maximum rated power circuit is 25A.
- Heater load shedding is set by default, so that the heater load sheds and turns off as soon as any device other than Pump 1 is switched on. The installer should consider this when determining the size of the power circuit required. Heater load shedding can be adjusted if desired. Refer to "Heater Load Shedding" section on page 18 of this manual for further information.

## Electrical Specifications

Model	Max Current	Input Voltage	Phases	Hz	Heater Size
Mini 1 / Mini 2	25A	230-240V AC	1	50/60	1.5kW / 2.0kW / 3.0kW

## Wiring Diagram (Mini 1)

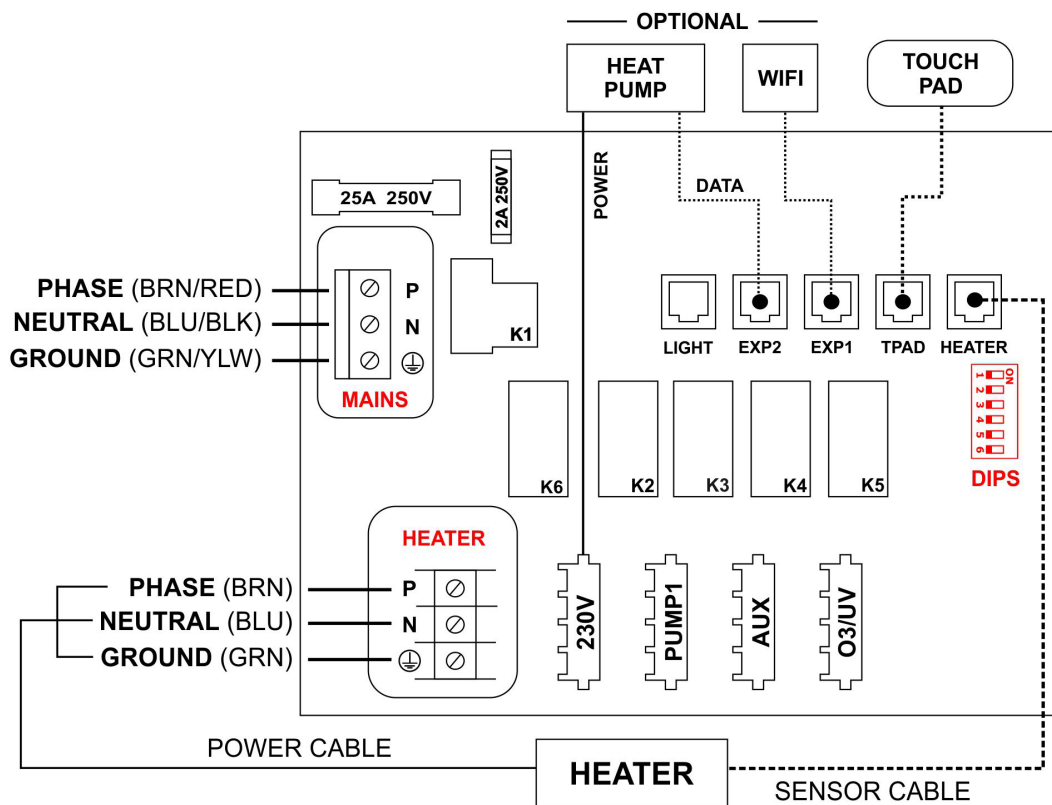

## Output Ratings

Model	Outlet	Max Current	Output Voltage	Hz	Typical Accessory
SV Mini 1	230V	10A	230-240V AC	50/60	Heat Pump / Stereo
	Pump 1	10A	230-240V AC	50/60	Circ / 2-spd or 1-spd Pump
	Aux	10A	230-240V AC	50/60	1-spd Pump / Air Blower
	03/UV	2A	230-240V AC	50/60	Ozone / UV Sanitiser

## Wiring Diagram (Mini 2)

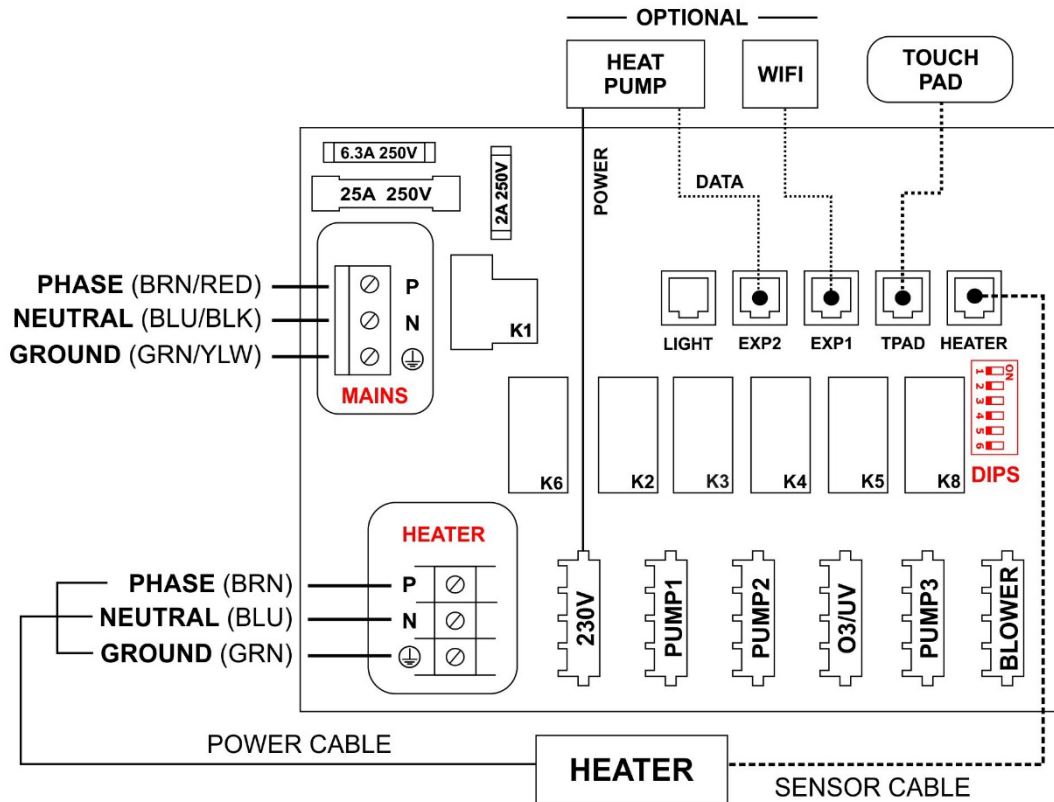

### Output Ratings

Model	Outlet	Max Current	Output Voltage	Hz	Typical Accessory
SV Mini 2	230V	10A	230-240V AC	50/60	Heat Pump / Stereo
	Pump 1	10A	230-240V AC	50/60	Circ / 2-spd or 1-spd Pump
	Pump 2	10A	230-240V AC	50/60	1-spd Pump
	O3/UV	2A	230-240V AC	50/60	Ozone / UV Sanitiser
	Pump 3	10A	230-240V AC	50/60	1-spd Pump
	Blower	4.5A	230-240V AC	50/60	Air Blower

## DIP SWITCHES

The dip switches determine the configuration of pumps connected to the SV Mini controllers. The installer must correctly configure the dip switches to match the pump(s) connected to the spa controller. The dip switch bank (illustrated below) has six individual switches. Switches set to the right of the switch bank (away from the numbers) are in the ON position. Switches set to the left of the switch bank (closest to the numbers) are in the OFF position. Refer to diagram below for dip switch settings:

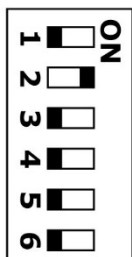

SW	Setting	OFF (left)	ON (right)	Notes
1	Not used	-	-	
2	Pump 1 Type	Single Speed	Two Speed	Determines if P1 = 1spd/2spd
3	Pump 3 Fitted *	Not Fitted	Fitted	Determines if P3 is connected
4	Not used	-	-	
5	Not used	-	-	
6	Not used	-	-	

\* SV Mini 2 models only

**NOTE:** The dip switches will already be set by your spa manufacturer during production and should not require adjusting. This information is for reference when installing a new control to an existing spa.

# SPA PACK INSTALLATION

## Floor Mounting Procedure



### **i** IMPORTANT NOTE

The spa pack is NOT intended to be used outdoors. The spa pack MUST be installed in indoor environments only and should be installed in an enclosure so that all electrical connections cannot be accessed without the use of a tool (i.e. under the spa cabinet).

### **The controller should be mounted vertically in a fixed position**

Select a suitable location on the spa base and firmly secure spa pack using four (4) x screws of appropriate length backed with flat washers.

Each screw should be positioned in the moulded cut outs of the mounting feet (refer aside). The spa pack should be fixed using ALL four (4) x screw locations to provide adequate support (two screws on each side of the spa pack, front and back).



Only use pan, round or truss head screws with flat washers



DO NOT use countersunk screws, they may damage or crack the mounting brackets

The spa pack should be located at least 10cm (4") above potential flood level. If spa floor is on ground level the spa pack should be raised 10cm (4") above floor level.

## Wall/Bracket Mounting Procedure



An adequate support structure for controller mounting must be provided. The structure should attach to the framework of the spa pool and NOT the spa pool shell itself, and shall be capable of supporting the weight of the controller.

Firmly secure spa pack to support frame using ALL four (4) x screw hole locations provided on the moulded mounting brackets (refer aside).



Only use pan, round or truss head screws with flat washers



DO NOT use countersunk screws, they may damage or crack the mounting brackets

### NOTES:

1. Install spa pack in a suitable position to prevent water dripping onto the unit. In particular, avoid installing spa pack directly underneath keypad or venturi air controls.

2. Waterproof bungs (supplied) MUST be installed on all unused AMP power sockets

# HEATER INSTALLATION

## Heater Sensors



The heater **MUST** be installed on a level horizontal plane only (as shown aside).

The heater **CANNOT** be laid on its side or on an angle. It must be orientated upright as pictured aside to ensure correct operation of the optical water sensor and thermal cut outs.

**HEATERS INSTALLED IN AN INCORRECT ORIENTATION WILL NOT BE COVERED BY THE SPANET PRODUCT WARRANTY.**

The heater can be plumbed on either suction or discharge lines however water should flow from the spa over the heater sensors first, then returning the heated water to the spa.

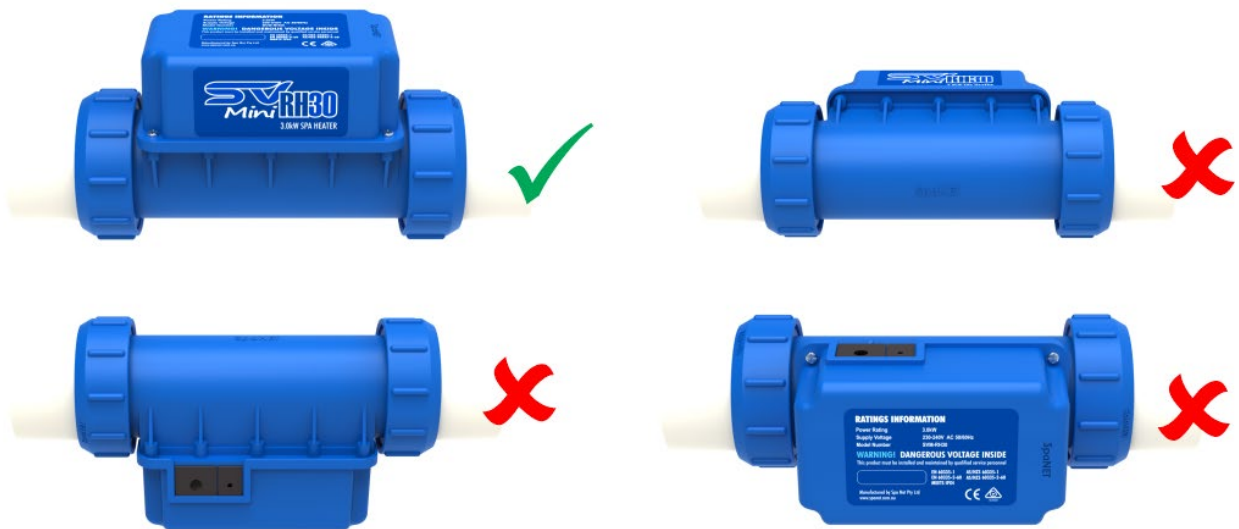

## Suggested Plumbing Installation

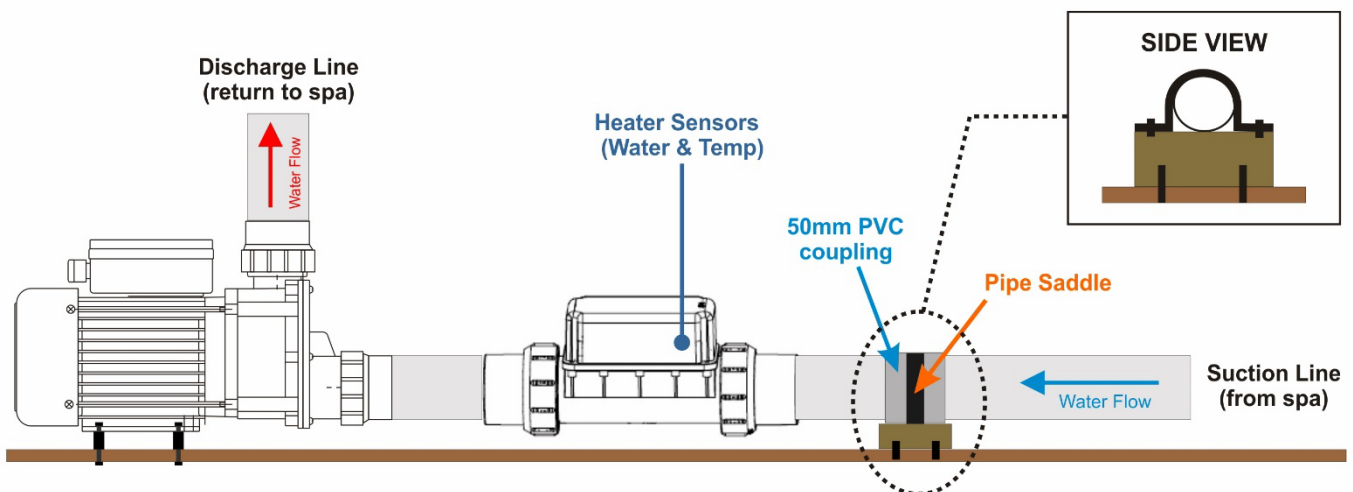

- The filtration pump and heater mac unions should be connected and tightened before plumbing to the spa

- The filtration pump should be installed in a level horizontal plane and must be securely fastened to the spa base or metal frame
- The heater should have sufficient clearance from the spa base to allow the mac unions to be easily unscrewed to enable servicing (if required)
- The heater should NOT be installed floating in mid-air on flexible pipe. We recommend installing close to the spa base plumbed with rigid pipe where possible (as pictured above)
- The heater can be installed on either the suction or discharge line however the heater MUST be orientated so that the water flows over the internal heater sensors first
- We recommend installing a pipe spacer support (that is securely fastened to the spa base or frame). A pipe saddle should then be used to secure the pipe work to the spacer support
- This design ensures all flex and movement created by water flow through the pipe work is absorbed by the secure point where the saddle is fitted and will minimise the chance of mac unions loosening over time

## Heater Terminal Connection

The 230V power to the heater is provided from the Heater Terminal Block on the SV Mini PCB. This is a high voltage, high current connection. It is extremely important that care is taken when connecting the heater wires, ensuring that all terminal connections and screws are tight and secure. Failure to complete this wire connection securely could cause excess heat, arcing and/or a burnt connection or PCB. **PRODUCT FAILURES AS A RESULT OF POOR CONNECTION AT THE HEATER TERMINAL BLOCK WILL NOT BE COVERED BY THE SPANET PRODUCT WARRANTY.**

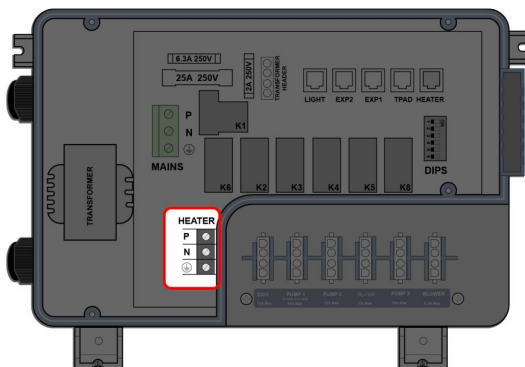

### IMPORTANT NOTE

Ensure heater wires are connected to the terminal block correctly and confirm that terminal screws are tight and secure.

**NOTE: A hand-held screwdriver should be used to complete the heater wire connections. Powered screwdrivers or impact drills can strip the screws and damage the PCB.**

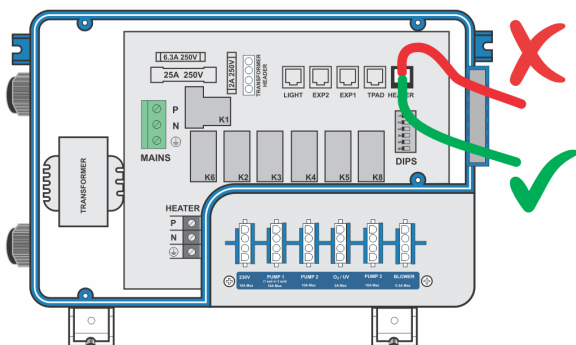

## Heater Sensor Cable Routing

Ensure sensor cable is routed DOWNWARDS, using one of the bottom cable grooves to secure in place (refer green line aside).

DO NOT route the sensor cable UP or cause the cable to bend on a tight radius



## Contact Us

### Spa Net Pty Ltd

Unit 1  
103 Mulgrave Road  
Mulgrave NSW 2756  
Australia

Phone: +61 2 4587 7766  
Fax: +61 2 4587 8766

**[www.spanet.com.au](http://www.spanet.com.au)**

Technical Support & Service [service@spanet.com.au](mailto:service@spanet.com.au)

Accounts Department [accounts@spanet.com.au](mailto:accounts@spanet.com.au)

Sales Department [sales@spanet.com.au](mailto:sales@spanet.com.au)