

## Keypad Dimensions

### SV2.T keypad

2.75" (70mm) LCD Screen

9 Keys

Blue LED Backlighting

165mm x 94mm x 33.50mm

2.5m lead length

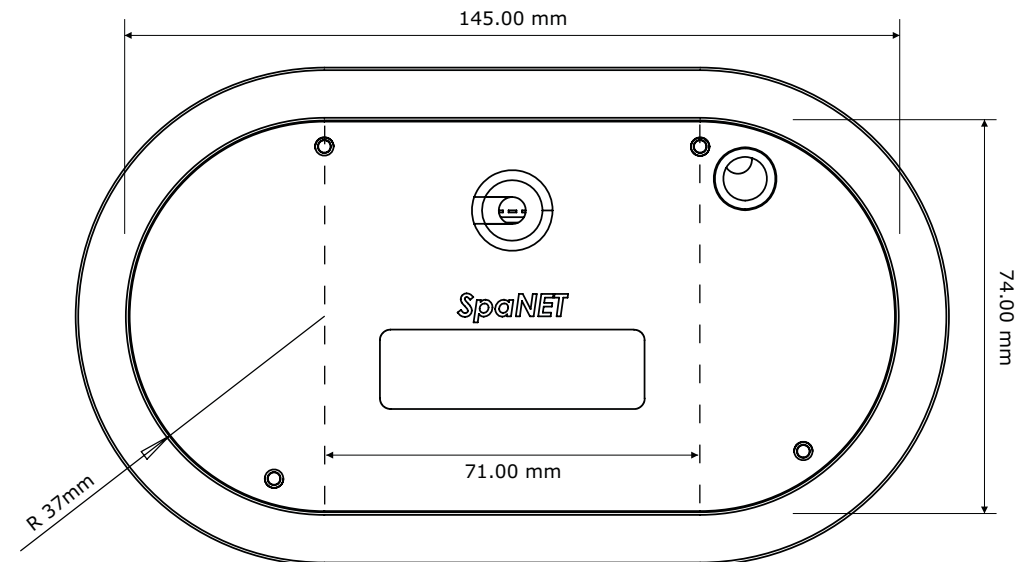
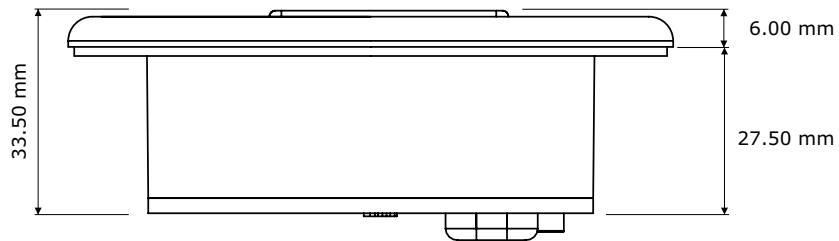
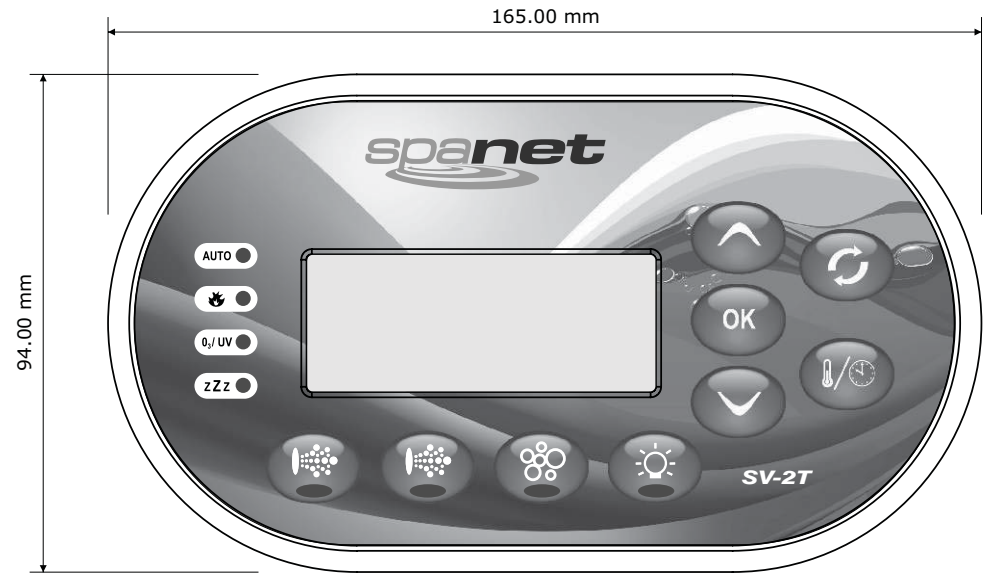

## Keypad Dimensions

SV3.T / SV4.T keypad

3.5" (90mm) LCD screen

12 keys

RGB colour mixing LED backlighting

185mm x 100mm x 33.50mm

2.5m lead length

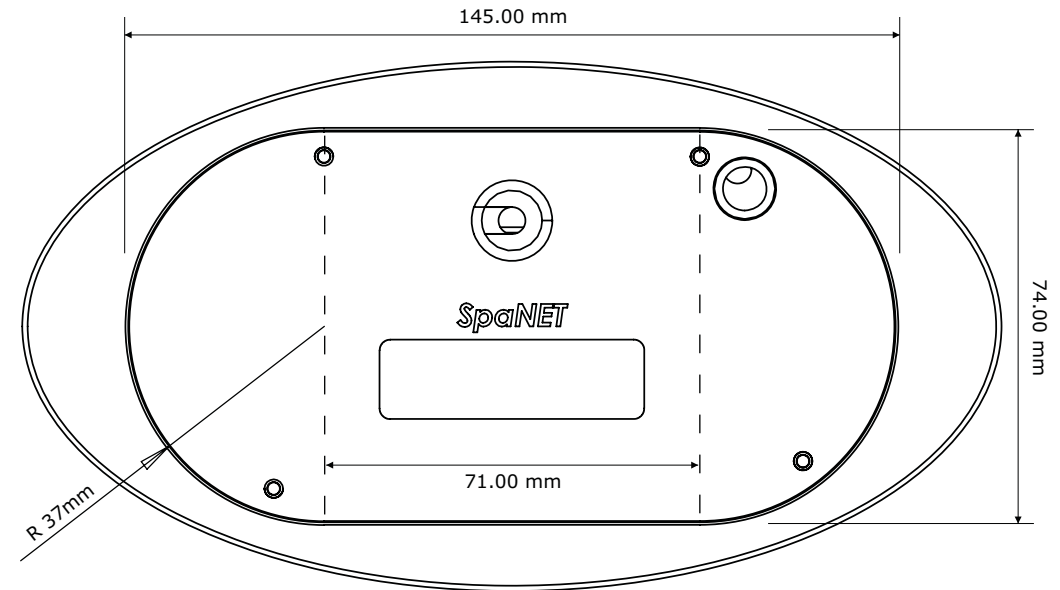
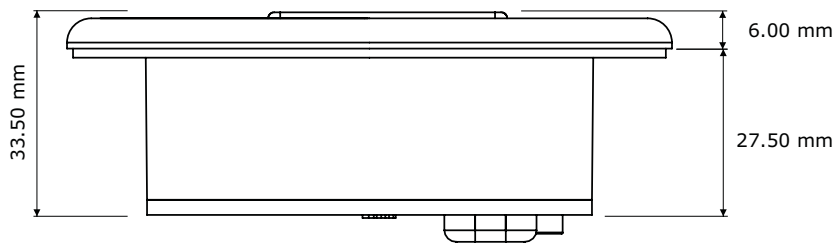
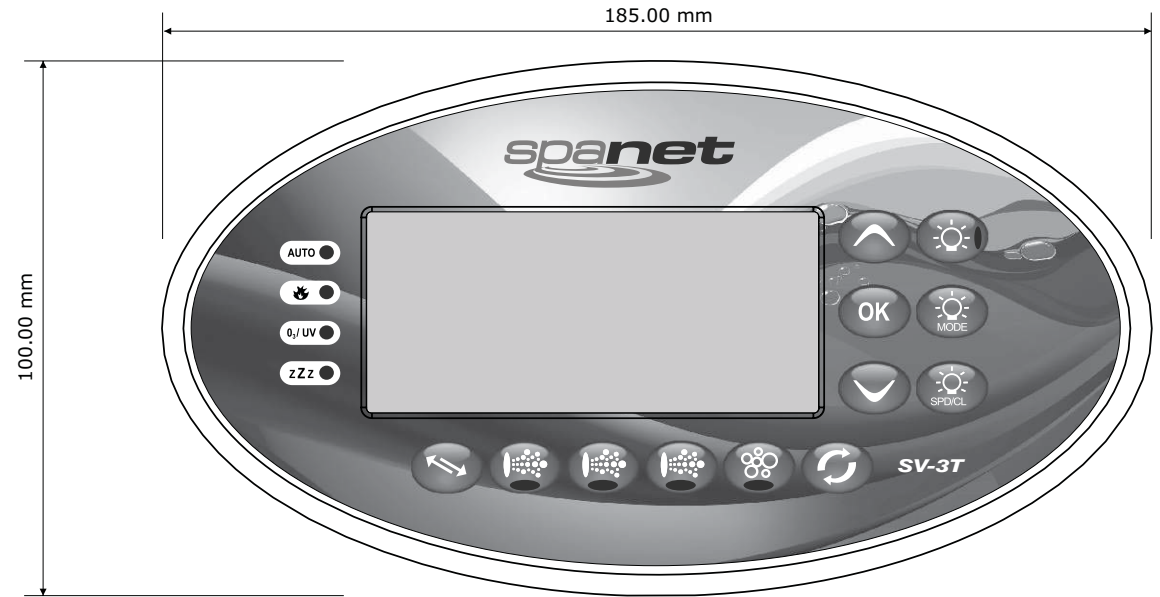

## Keypad Installation

All Models (SV2.T / SV3.T / SV4.T)

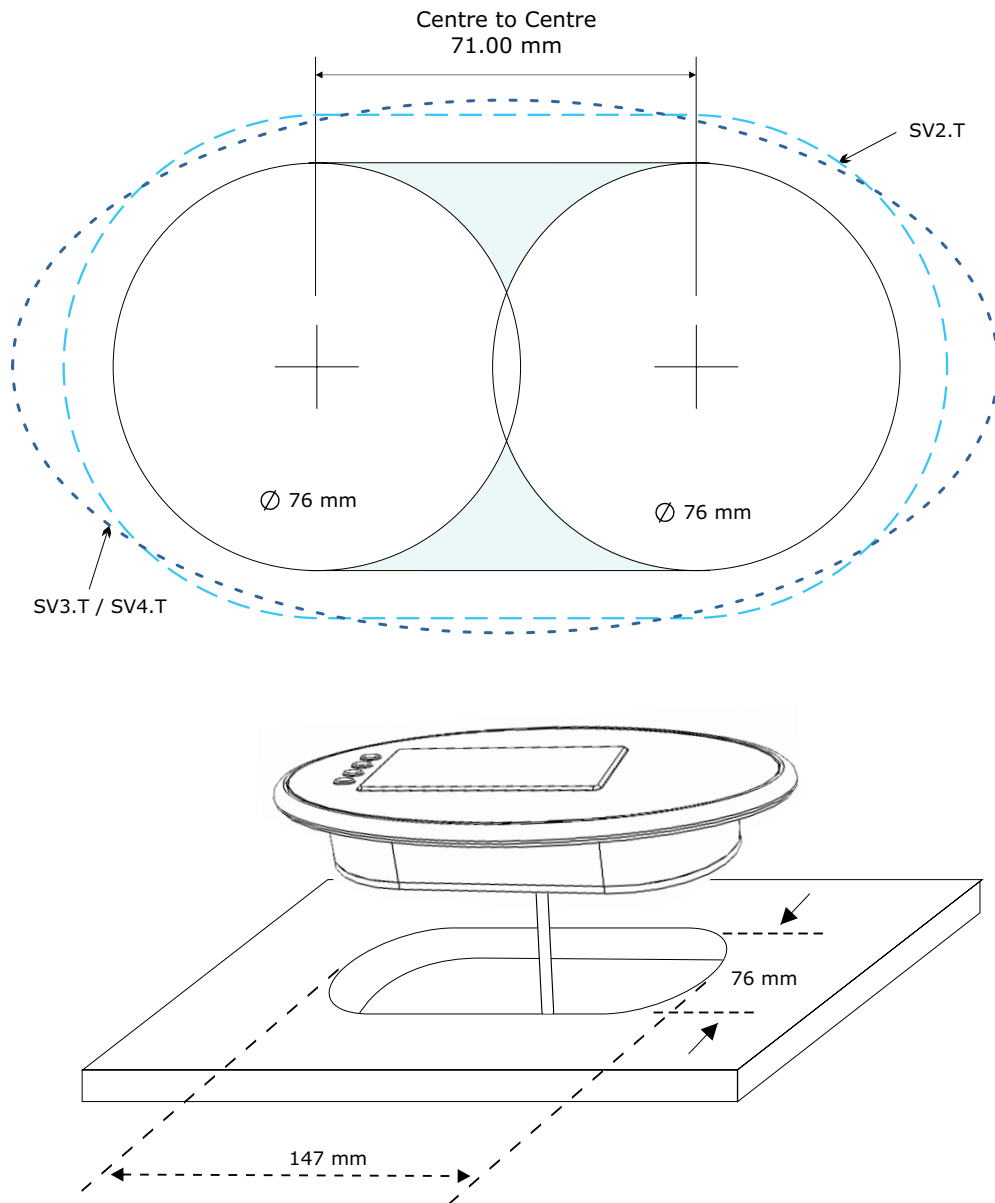

- ▶ Select a suitable keypad location that is above maximum water level and that is easily accessible to the spa user.
- ▶ Before drilling the cut out for the keypad, hold the keypad in place and check there is sufficient cable length to reach the spa pack without the cable being stretched or pulled against sharp edges.

Drill two 76mm diameter holes spaced 71mm apart from centre to centre (as illustrated aside).

Cut out the residual material between the two holes (as illustrated).

Clean mounting surface to be free of dirt and dust particles, oil and grease. To ensure the keypad adhesive bonds to the spa well the shell must have a clean, smooth and dry surface.

Peel paper backing from adhesive gasket ensuring all of the adhesive is exposed.

Feed cable through opening, align keypad and press firmly onto mounting surface. Ensure keypad is adhered well to surface by pressing evenly around the outside edge of the whole keypad.

### IMPORTANT NOTES

- The keypad mounting location should have adequate drainage to prevent accumulation of water on or around the keypad area.
- If keypad is to be mounted under a spa cover allow sufficient clearance to prevent cover resting directly on keypad.
- Parts incorporating electrical components (ie. keypads) must be fixed so that they cannot fall into the bath or spa

# SVT Keypad Cut Out Template

SV2.T / SV3.T / SV4.T (Scale 1:1)

**NOTE:** To print in 1:1 scale, set Page Scaling to NONE in the print dialog box

